

ENGINE CONTROL AND ENGINE IMMOBILISER SYSTEM

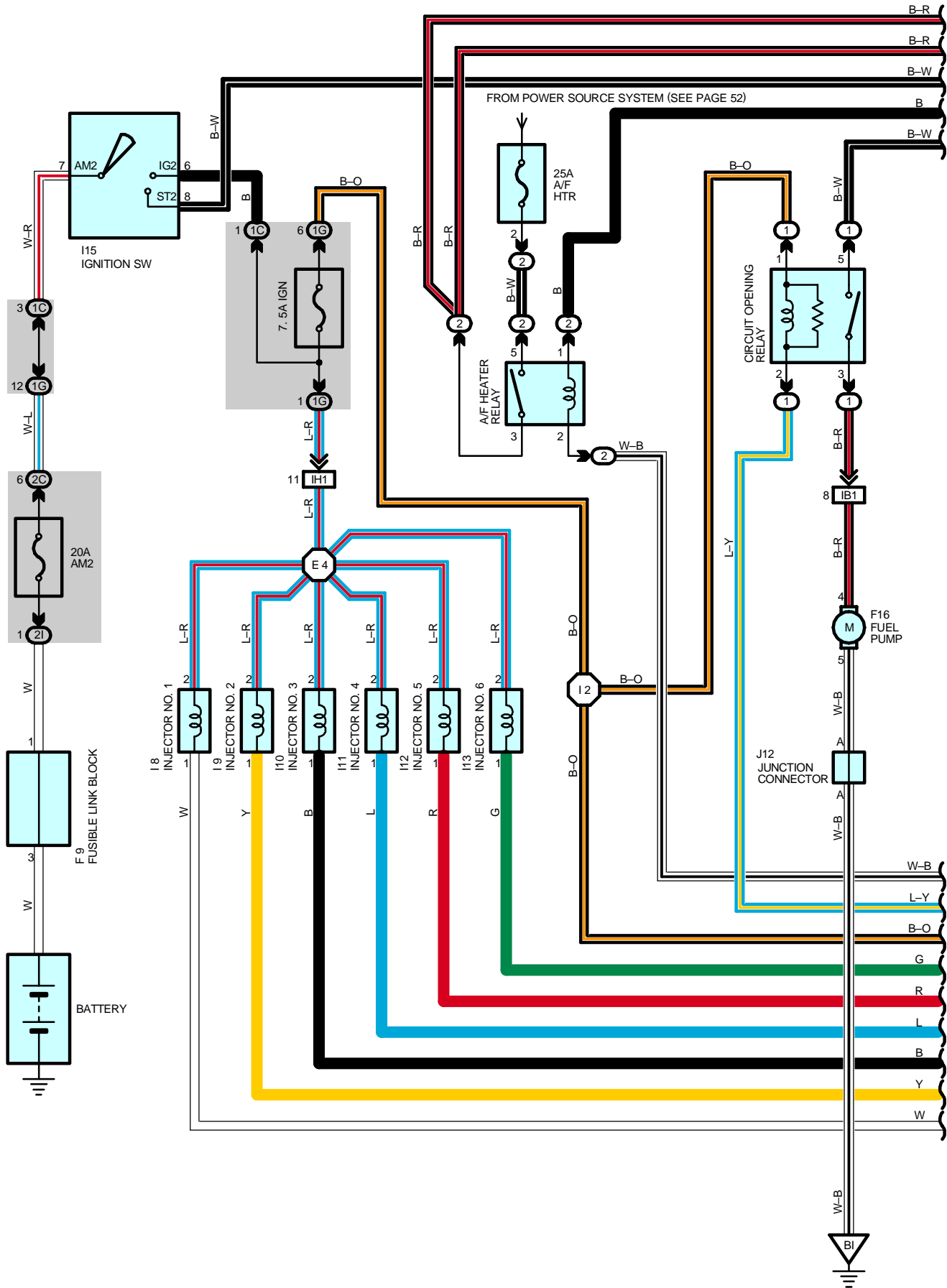

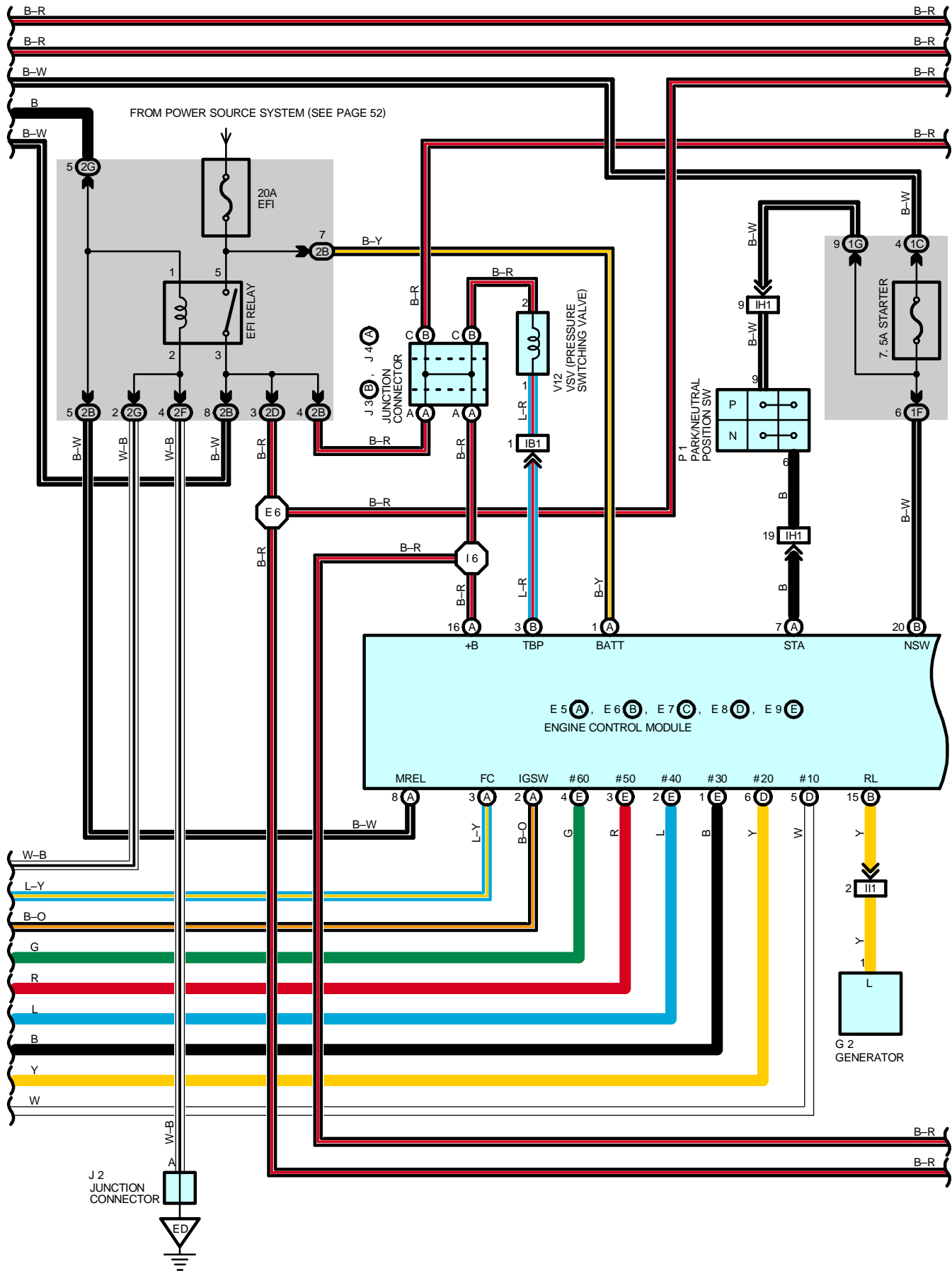

ENGINE CONTROL AND ENGINE IMMOBILISER SYSTEM

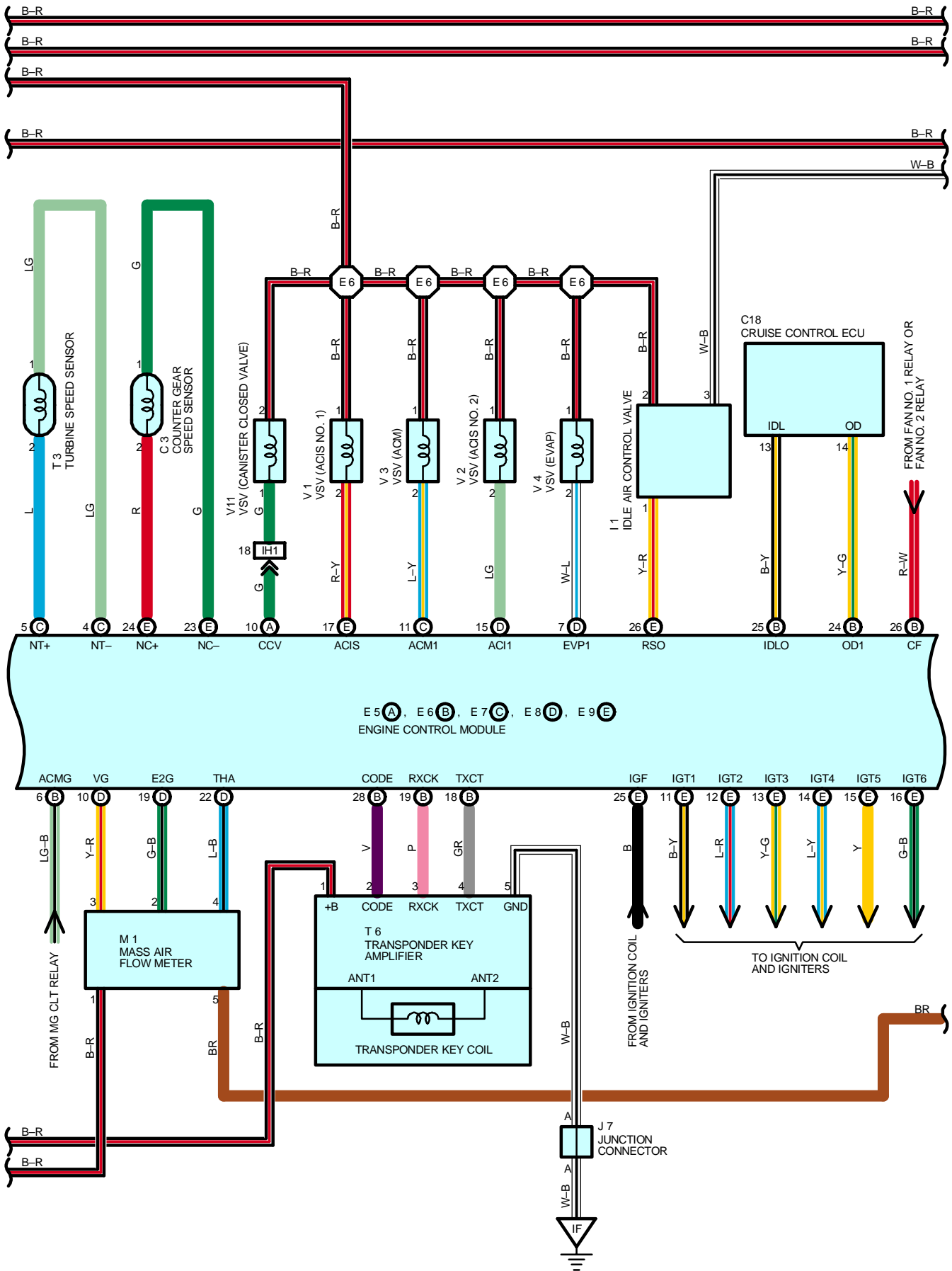

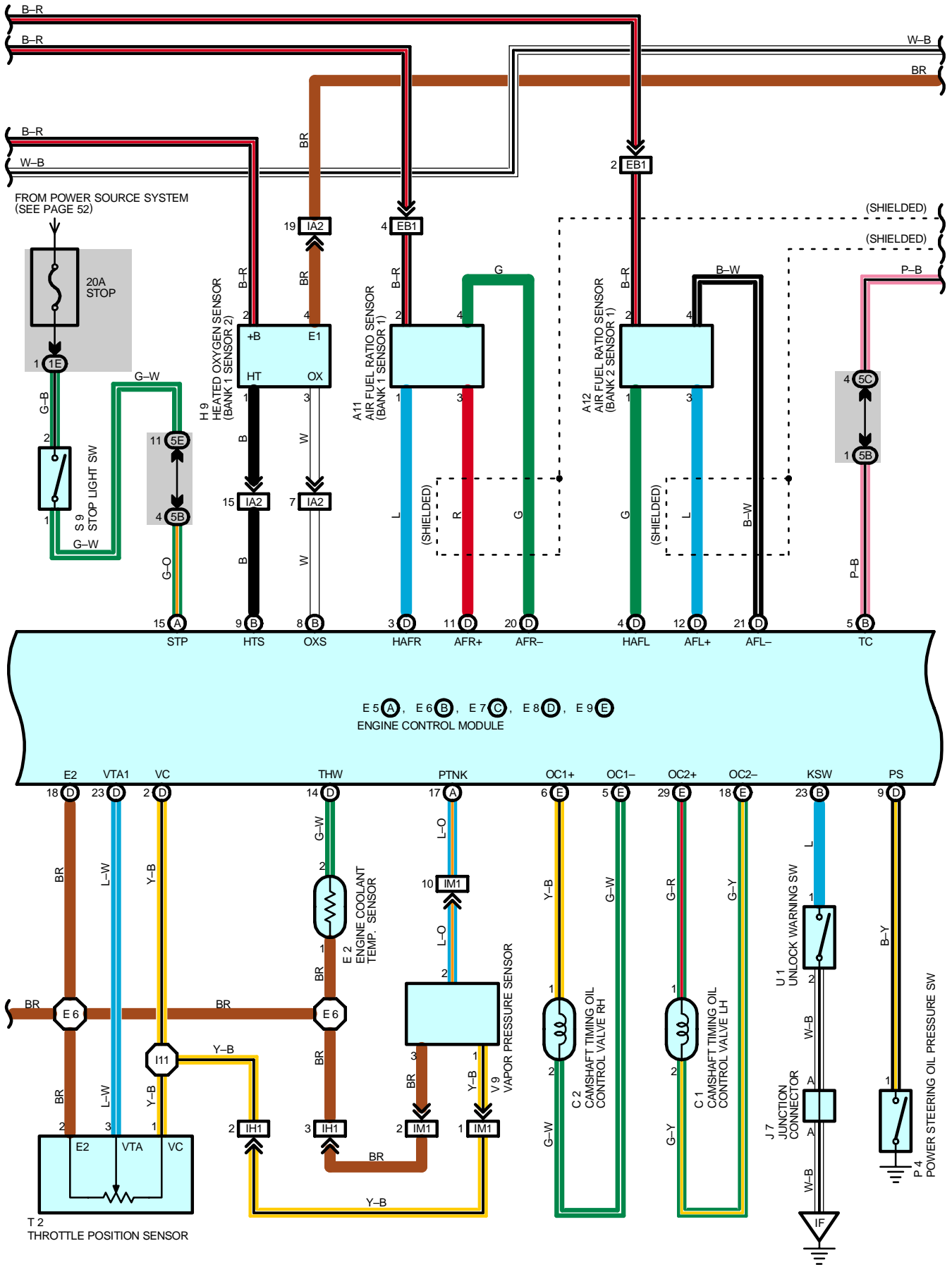

ENGINE CONTROL AND ENGINE IMMOBILISER SYSTEM

SYSTEM OUTLINE

The engine control system utilizes a microcomputer and maintains overall control of the engine, transmission etc. An outline of the engine control is given here.

1. INPUT SIGNALS

- (1) Engine coolant temp. signal circuit
The engine coolant temp. sensor detects the engine coolant temp. and has a built-in thermistor with a resistance, which varies according to the engine coolant temp. The engine coolant temp. which is input into TERMINAL THW of the engine control module as a control signal.
- (2) Intake air temp. signal circuit
The intake air temp. sensor is installed in the mass air flow meter and detects the intake air temp. which is input as a control signal to TERMINAL THA of the engine control module.
- (3) Vehicle speed signal circuit
The vehicle speed signal is input from the ABS speed sensor to ABS & BA & TRAC & VSC ECU, and are sent to the engine control module through communication control.
- (4) RPM signal circuit
Camshaft position is detected by the VVT sensors and its signal is input to TERMINALS VV1+ and VV2+ of the engine control module as a control signal. Also, engine RPM is detected by the crankshaft position sensor and is input as a control signal to TERMINAL NE+.
- (5) Throttle position signal circuit
The throttle position sensor detects the throttle valve opening angle as a control signal, which is input into TERMINAL VTA1 of the engine control module.
- (6) Battery signal circuit
Voltage is constantly applied to TERMINAL BATT of the engine control module. With the ignition SW turned on, the voltage for engine control module start-up power supply is applied to TERMINAL +B of the engine control module via the EFI relay.
The current flowing through the IGN fuse flows to TERMINAL IGSW of the engine control module.
- (7) Intake air volume signal circuit
Intake air volume is detected by the mass air flow meter and the signal is input to TERMINAL VG of the engine control module as a control signal.
- (8) Stop light SW signal circuit
The stop light SW is used to detect whether the vehicle is braking or not and the signal is input into TERMINAL STP of the engine control module as a control signal.
- (9) Starter signal circuit
To confirm whether the engine is cranking, the voltage is applied to the starter motor during cranking is detected and the signal is input into TERMINAL STA of the engine control module as a control signal.
- (10) Engine knock signal circuit
Engine knocking is detected by knock sensors and the signal is input into TERMINALS KNKL and KNKR as a control signal.

2. CONTROL SYSTEM

- * SFI system
The SFI system monitors the engine condition through the signals input from each sensor (Input signals from (1) to (10) etc.) to the engine control module. And the control signal is output to TERMINALS #10, #20, #30, #40, #50 and #60 of the engine control module to operate the injector (Inject the fuel). The SFI system controls the fuel injection operation by the engine control module in response to the driving conditions.
- * ESA system
The ESA system monitors the engine condition through the signals input to the engine control module from each sensor (Input signals from (1) to (10) etc.). The best ignition timing is decided according to this data and the memorized data in the engine control module and the control signal is output to TERMINALS IGT1, IGT2, IGT3, IGT4, IGT5 and IGT6. This signal controls the igniter to provide the best ignition timing for the driving conditions.
- * ACIS
The ACIS includes a valve in the bulkhead separating the surge tank into two parts. This valve is opened or closed according to the driving conditions to control the intake manifold length in three stages, for increased engine output in all ranges from low to high speeds, when idling.

3. DIAGNOSIS SYSTEM

With the diagnosis system, when there is a malfunction in the engine control module signal system, the malfunctioning system is recorded in the memory. The malfunctioning system can be found by reading the code displayed by the check engine warning light.

4. FAIL-SAFE SYSTEM

When a malfunction has occurred in any system, if there is a possibility of engine trouble being caused by continued control based on the signals from that system, the fail-safe system either controls the system by using data (Standard values) recorded in the engine control module memory or else stops the engine.

SERVICE HINTS

CIRCUIT OPENING RELAY

5-3 : Closed with the starter running

EFI RELAY

5-3 : Closed with the ignition SW at **ON** or **ST** position

E5 (A), E6 (B), E7 (C), E8 (D), E9 (E) ENGINE CONTROL MODULE

Voltage at engine control module wiring connector

BATT-E1 : Always **9.0-14.0** volts

+B-E1 : **9.0-14.0** volts (Ignition SW at **ON** position)

VC-E2 : Always **4.5-5.5** volts (Ignition SW at **ON** position)

VT A1-E2 : **0.3-0.8** volts (Ignition SW on and throttle valve fully closed)

3.2-4.9 volts (Ignition SW on and throttle valve fully open)

VG-E2G : **1.1-1.5** volts (Engine idling and A/C SW off)

THA-E2 : **0.5-3.4** volts (Engine idling and intake air temp. **20°C, 68°F**)

THW-E2 : **0.2-1.0** volts (Engine idling and coolant temp. **80°C, 176°F**)

IGF-E1 : **4.5-5.5** volts (Ignition SW at **ON** position)

Pulse generation (Engine idling)

SIL-E1 : Pulse generation (During transmission)

TACH-E1 : Pulse generation (Engine idling)

STA-E1 : **6.0** volts or more (Engine cranking)

FC-E1 : **9.0-14.0** volts (Ignition SW at **ON** position)

0-3.0 volts (Engine idling)

SPD-E1 : Pulse generation (Ignition SW on and rotate driving wheel slowly)

W-E1 : Below **3.0** volts (Ignition SW at **ON** position)

NSW-E1 : **9.0-14.0** volts (Ignition SW on and other shift position in **P** or **N** position)

0-3.0 volts (Ignition SW on and shift position in **P** or **N** position)

EVP1-E01 : **9.0-14.0** volts (Ignition SW at **ON** position)

TC-E1 : **9.0-14.0** volts (Ignition SW at **ON** position)

STP-E1 : **7.5-14.0** volts (Ignition SW on and brake pedal depressed)

0-1.5 volts (Ignition SW on and brake pedal depressed)

TBP-E1 : **9.0-14.0** volts (Ignition SW on and disconnect the vacuum hose from the vapor pressure sensor)

PTNK-E1 : **3.0-3.6** volts (Ignition SW at **ON** position)

1.3-2.1 volts (Ignition SW on and apply vacuum **2.0** kpa)

OXS-E1 : Pulse generation (Maintain engine speed at **2500** rpm for two minutes after warming up)

KNKL, KNKR-E1 : Pulse generation (Engine idling)

IGT1, IGT2, IGT3, IGT4, IGT5, IGT6-E1 : Pulse generation (Engine idling)

#10, #20, #30, #40, #50, #60-E01 : **9.0-14.0** volts (ignition SW at **ON** position)

Pulse generation (Engine idling)

ENGINE CONTROL AND ENGINE IMMOBILISER SYSTEM

○ : PARTS LOCATION

Code	See Page	Code	See Page	Code	See Page
A11	32	F16	36	M1	33
A12	32	G2	32	O1	33
B5	A 34	H9	36	P1	33
B8	D 34	I1	33	P4	33
C1	32	I8	33	R11	37
C2	32	I9	33	R13	37
C3	32	I10	33	S9	35
C4	32	I11	33	T2	33
C12	A 34	I12	33	T3	33
C14	C 34	I13	33	T6	35
C18	34	I15	35	U1	35
D4	34	I16	A 35	V1	33
D17	36	I18	B 35	V2	33
E2	32	J2	33	V3	33
E5	A 35	J3	B 35	V4	33
E6	B 35	J4	A 35	V5	33
E7	C 35	J7	35	V6	33
E8	D 35	J10	35	V9	37
E9	E 35	J12	36	V11	33
F9	32	K1	33	V12	37
F15	36	K2	33		

○ : RELAY BLOCKS

Code	See Page	Relay Blocks (Relay Block Location)
1	29	R/B No.1 (Lower Finish Panel)
2	30	R/B No.2 (Engine Compartment Left)

○ : JUNCTION BLOCK AND WIRE HARNESS CONNECTOR

Code	See Page	Junction Block and Wire Harness (Connector Location)
1C	22	Cowl Wire and Instrument Panel J/B (Lower Finish Panel)
1E		
1F		
1G		
1K	22	Instrument Panel Wire and Instrument Panel J/B (Lower Finish Panel)
2B	24	Cowl Wire and Engine Room J/B (Engine Compartment Left)
2C		
2D	24	Engine Wire and Engine Room J/B (Engine Compartment Left)
2F	24	Engine Room Main Wire and Engine Room J/B (Engine Compartment Left)
2G		
2I		
3A	26	Instrument Panel Wire and J/B No.3 (Behind the Instrument Panel Center)
3B		
3E		
3K		
5A	28	Cowl Wire and J/B No.5 (Behind the Instrument Panel Left)
5B		
5C		
5E		

 : CONNECTOR JOINING WIRE HARNESS AND WIRE HARNESS

Code	See Page	Joining Wire Harness and Wire Harness (Connector Location)
EA1	40	Engine Wire and Sensor Wire (Head Cover RH)
EB1	40	Engine Wire and Engine Room Main Wire (Under the Engine Room J/B)
IA2	42	Cowl Wire and Floor No.2 Wire (Left Kick Panel)
IB1	42	Floor No. 2 Wire and Cowl Wire (Left Kick Panel)
IC1	42	Front Door LH Wire and Cowl Wire (Left Kick Panel)
IE1	42	Instrument Panel Wire and Cowl Wire (Lower Finish Panel)
IE2		
IH1	44	Engine Wire and Cowl Wire (Behind the Glove Box)
II1	44	Engine Room Main Wire and Cowl Wire (Cowl Side Panel RH)
IJ1	44	Cowl Wire and Instrument Panel Wire (Behind the Glove Box)
IL1	44	Front Door RH Wire and Cowl Wire (Right Kick Panel)
IM1	44	Cowl Wire and Floor Wire (Right Kick Panel)
BA1	46	Rear Door LH Wire and Floor No.2 Wire (Under the Left Center Pillar)
BB1	46	Rear Door RH Wire and Floor Wire (Under the Right Center Pillar)
BD1	46	Floor No.2 Wire and Floor Wire (Upper the Rear Axle Housing Left)

 : GROUND POINTS

Code	See Page	Ground Points Location
EB	40	Surge Tank RH
EC	40	Rear Side of Surge Tank
ED	40	Right Radiator Side Support
IF	42	Dash Panel Center
IH	42	Instrument Panel Brace RH
BI	46	Upper the Rear Axle Housing Left

 : SPLICE POINTS

Code	See Page	Wire Harness with Splice Points	Code	See Page	Wire Harness with Splice Points
E4	40	Engine Wire	I6	44	Cowl Wire
E5			I11	44	Engine Wire
E6			I12	44	Cowl Wire
I2	44	Cowl Wire			